



Possibilities of VPP application in blast mitigation seats

Dominik Rodak¹, Mateusz Żurawski¹, Robert Zalewski¹, Michał Gmitrzuk², Lech Starczewski²

¹Warsaw University of Technology, 02-524 Warszawa, Poland

²Military Institute of Armoured and Automotive Technology, 05-070 Sulejówek, Poland



VPP simulations

- 4 DOFs dynamic model
- Johnson – Cook model
- P1 = 0.05 MPa, P2 = 0.09 MPa
- Comparable with lab. Tests

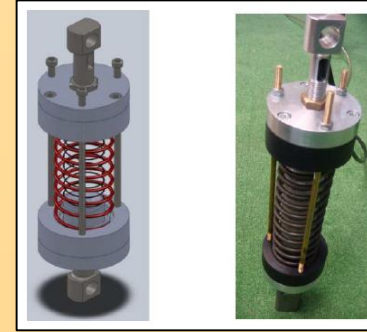
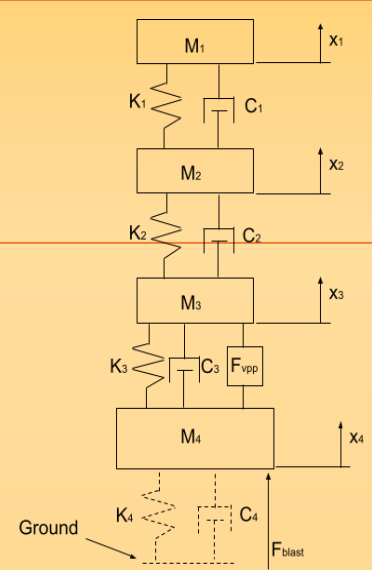

VPP linear damper

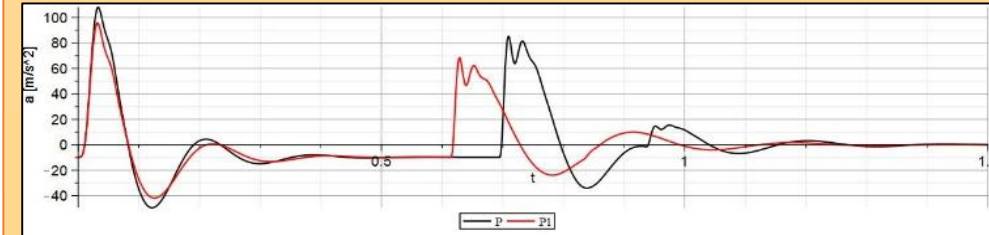

Pelvis acceleration for P1=0,05 MPa

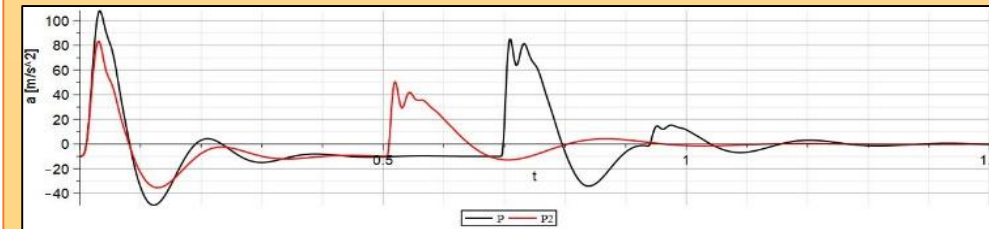

Pelvis acceleration for P2=0,09 MPa

Laboratory Tests

- Impact bench
- ATD Hybrid III
- Pulse generator
- Comparable with field tests

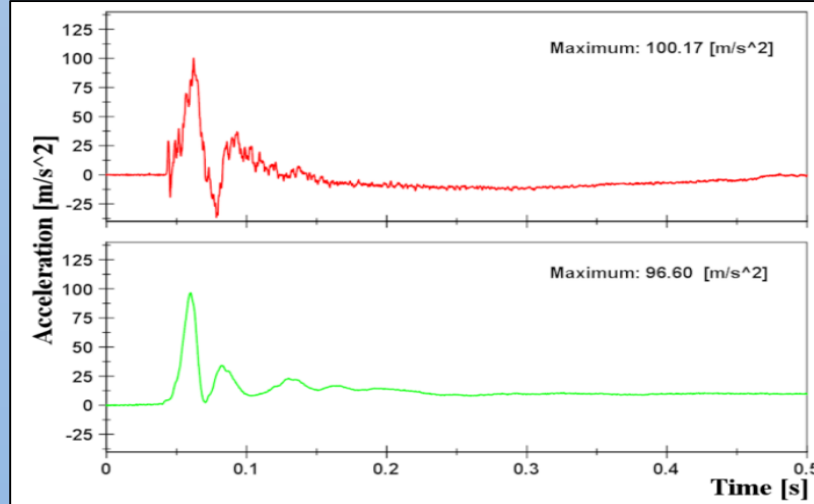
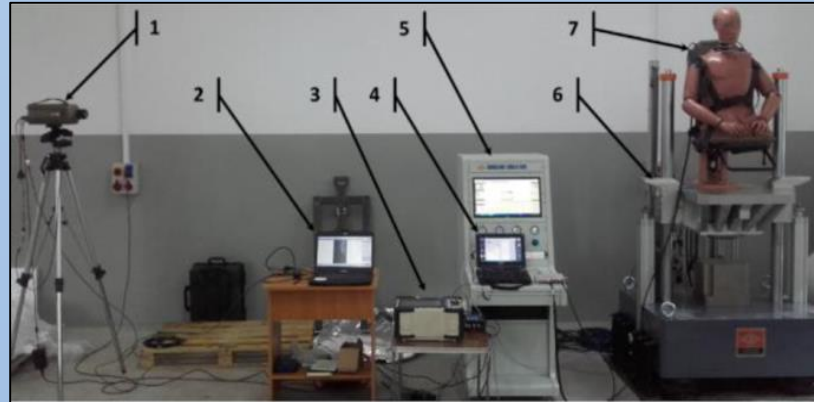

Hybrid III pelvic acceleration; Field tests and lab. tests (respectively)

The poster presents a possibility of an application of the linear Vacuum Packed Particle (VPP) damper as a supplementation for a viscous shock absorber in a traditional blast mitigation seat design.

October 2010 - September 2020

- 171,000 people were killed because of IEDs.
- 2.640 soldiers killed by IEDs (US Army)
- 73% roadside bombs

Blast mitigation methods

- V – shaped floors.
- Seats mounted to the roof/sides
- Blast mitigation seats with various dampers

Field Tests

- 8kg TNT
- Blast mitigation seat inside
- ATD Hybrid III



Conclusions

- Impact bench tests are comparable with field tests
- VPP damper allows to reduce acceleration during the blast excitation
- VPP should be examined as a supplementary damper in the blast mitigation seat